

NUOVE TESTE PER ALESARE BILAMA "BLT..." NEW TWIN CUTTER BORING HEAD "BLT..."

ATTACCO A TRASCINAMENTO FRONTALE
ATTACHMENT "FACE DRIVING" FIT

NEW

INSERTI TC../CC..
90° E 75°
TC../CC.. INSERTS
90° AND 75°

DIAMETRO REGOLABILE
ADJUSTABLE DIAMETER

**SAU**
QUALITY TOOLS ENGINEERING

BLT .. 075 ..W

Ø 40-210

NEW

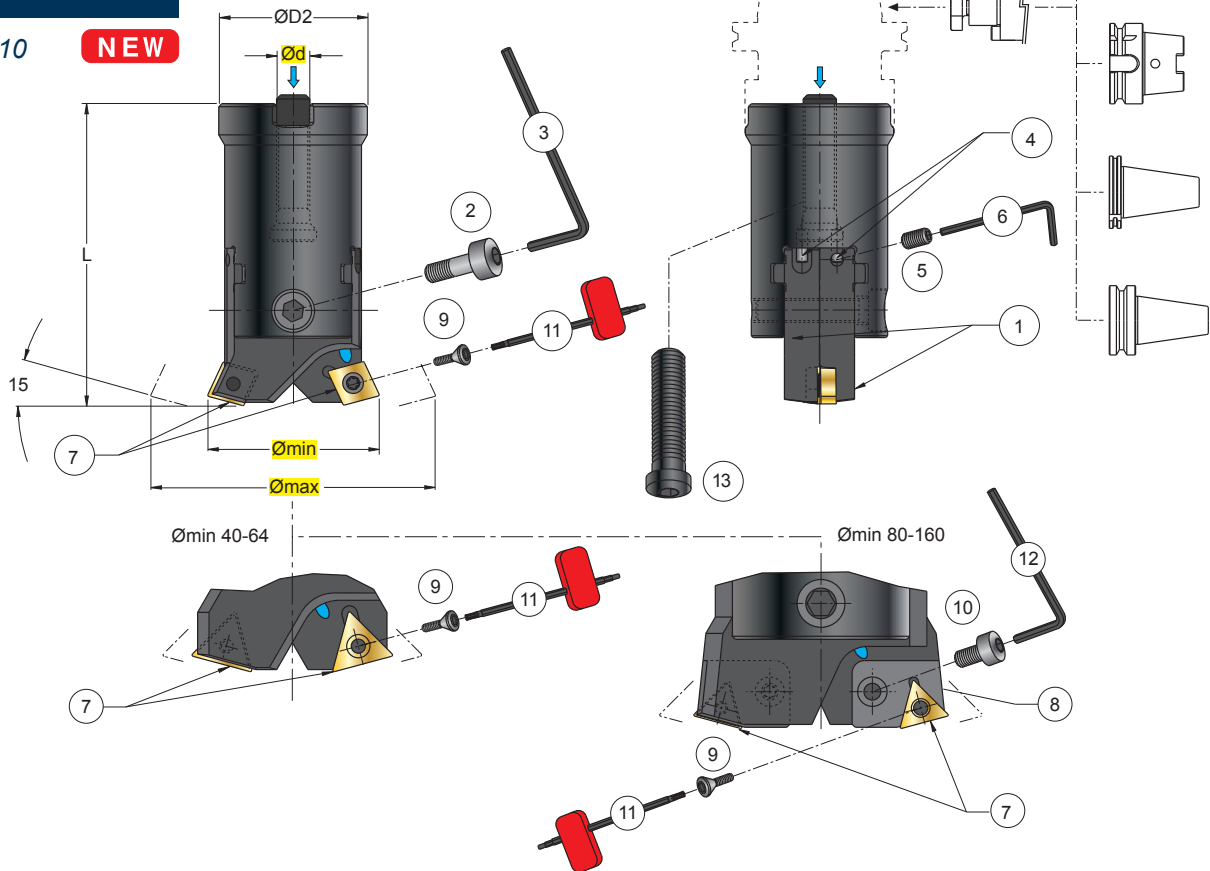

ART.	Prezzo Listino Price List (€)	Dimensioni (mm)					kg	Accessori												
		Ømin-max	Ød	ØD2	L			1	2	3	4	5	6	8	9	10	11	12	13	7
BLT.040.075.C09W	624,00	40-51	16	38	77	0,30	LMA.040.075.C09W	VBL06BL	5005	3098	GRB4C	5002	-	12409P	-	5515P	-	VDST 2008	CC..09	
BLT.050.075.T16W	685,00	50-65	22	48	85	0,50	LMA.050.075.T16W	VBL06L	5005	3098	GRB4	5002	-	12409P	-	5515P	-	VBSF 10AV	TC..16	
BLT.064.075.T16W	855,70	64-82	27	60	101	0,90	LMA.064.075.T16W	VBL08	5006	3098	GRB4L	5002	-	1240P	-	5515P	-	VBSF 12		
BLT.080.075.CA1W	1.236,50	80-102	32	75	116	1,44	LMA.080.000.000W	VBL10C	5008	4158	901.006 040.010	5003	CA1-75	12409P	VBL6C	5515P	5005	VBSF 16		
BLT.080.075.CA3W	1.244,20	80-102	32	75	116	1,44	LMA.080.000.000W	VBL10C	5008	4158	901.006 040.010	5003	CA3-75	124510P	VBL6C	5520P	5005	VBSF 16	SC..12	
BLT.100.075.CA1W	1.564,50	100-126	32	80	121	2,12	LMA.100.000.000W	VBL10	5008	4158	GRB6C	5003	CA1-75	12409P	VBL6C	5515P	5005	VBSF 16	TC..16	
BLT.100.075.CA3W	1.572,20	100-126	32	80	121	2,12	LMA.100.000.000W	VBL10	5008	4158	GRB6C	5003	CA3-75	124510P	VBL6C	5520P	5005	VBSF 16	SC..12	
BLT.125.075.CA1W	1.790,00	125-162	32	80	121	3,30	LMA.125.000.000W	VBL10L	5008	4158	GRB6	5003	CA1-75	12409P	VBL6C	5515P	5005	VBSF 16	TC..16	
BLT.125.075.CA3W	1.790,00	125-162	32	80	121	3,30	LMA.125.000.000W	VBL10L	5008	4158	GRB6	5003	CA3-75	124510P	VBL6C	5520P	5005	VBSF 16	SC..12	
BLT.160.075.CA1W	1.807,00	160-210	32	80	121	4,30	LMA.160.000.000W	VBL10L	5008	4158	GRB6L	5003	CA1-75	12409P	VBL6C	5515P	5005	VBSF 16	TC..16	
BLT.160.075.CA3W	1.807,00	160-210	32	80	121	4,30	LMA.160.000.000W	VBL10L	5008	4158	GRB6L	5003	CA3-75	124510P	VBL6C	5520P	5005	VBSF 16	SC..12	

CA ..-75



TC.. 16T3



SC.. 1204



CARTUCCE PER TESTA PER ALESARE BILAMA
 CARTRIDGES FOR TWIN CUTTER BORING HEADS
 EINBAUHALTER FÜR ZWEISCHNEIDEN-AUSDREHKOPF
 CARTOUCHES POUR TÊTE D'ALÉSAGE DOUBLE TRANCHANT

ART.	Prezzo Listino Price List (€)	Dimensioni (mm)			kg	Nm	Accessori		Accessori		Accessori	
		f	h	L			16T3	1204	12409P	5515P	VBL06C	5005
CA1-75	112,30	16,47	12,27	30	0,035	3,8+5,0	16T3	-	12409P	5515P	VBL06C	5005
CA3-75	112,30	16,47	12,27	30	0,035	4,0+5,0	-	1204	124510P	5520P	VBL06C	5005

BLT .. 090 ..W

Ø 40-210

NEW

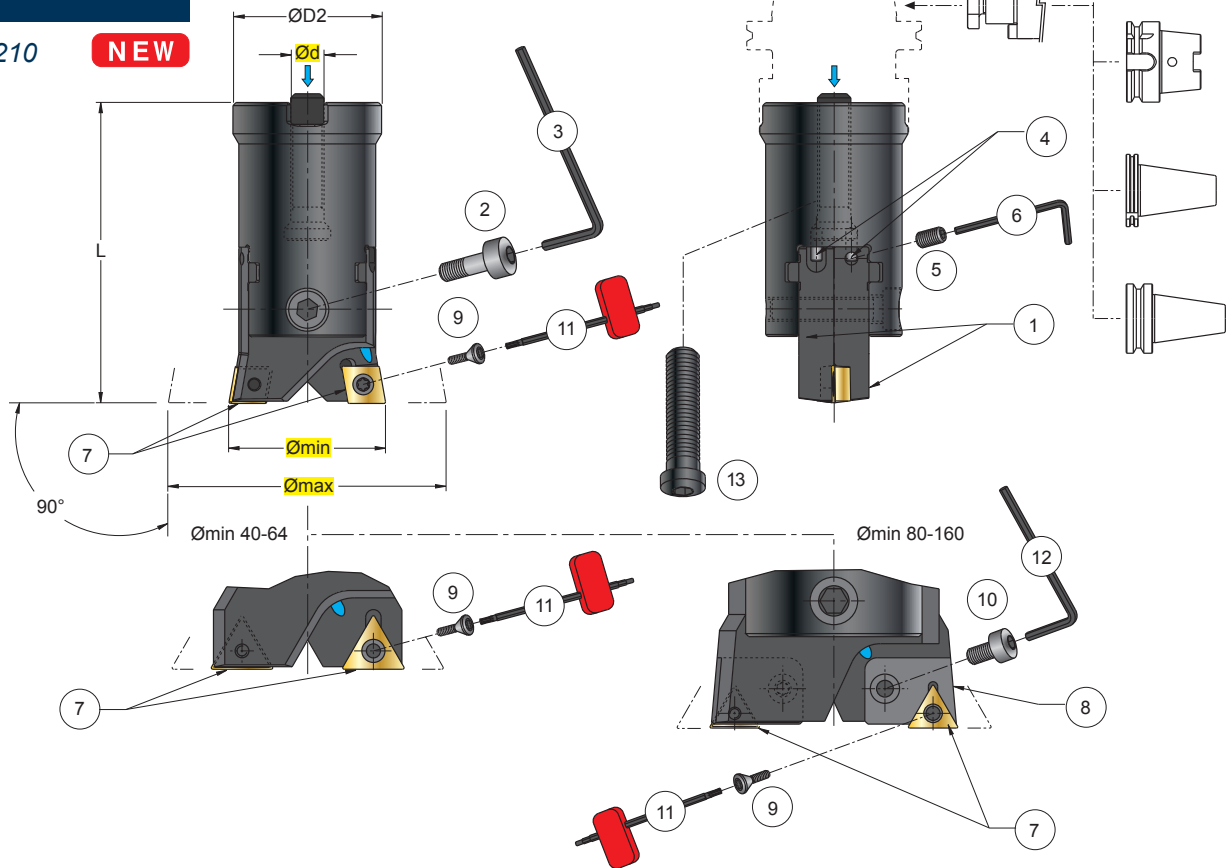

ART.	Prezzo Listino Price List (€)	Prezzi (mm)					kg	Accessories												
		Ømin-max	Ød	ØD2	L			1	2	3	4	5	6	8	9	10	11	12	13	7
BLT.040.090.C09W	599,00	40-51	16	38	77	0,30	LMA.040.090.C09W	VBL06BL	5005	3098	GRB4C	5002	-	12409P	-	5515P	-	VDST 2008	CC..09	
BLT.050.090.T16W	663,00	50-65	22	48	85	0,50	LMA.050.090.T16W	VBL06L	5005	3098	GRB4	5002	-	12409P	-	5515P	-	VBSF 10AV	TC..16	
BLT.064.090.T16W	718,00	64-82	27	60	101	0,90	LMA.064.090.T16W	VBL08	5006	3098	GRB4L	5002	-	1240P	-	5515P	-	VBSF 12		
BLT.080.090.CA1W	1.219,20	80-102	32	75	116	1,44	LMA.080.000.000W	VBL10C	5008	4158	901.006.040.010	5003	CA1-90	12409P	VBL6C	5515P	5005	VBSF 16		
BLT.080.090.CA2W	1.221,80	80-102	32	75	116	1,44	LMA.080.000.000W	VBL10C	5008	4158	901.006.040.010	5003	CA2-90	124510P	VBL6C	5520P	5005	VBSF 16	CC..12	
BLT.100.090.CA1W	1.547,20	100-126	32	80	121	2,12	LMA.100.000.000W	VBL10	5008	4158	GRB6C	5003	CA1-90	12409P	VBL6C	5515P	5005	VBSF 16	TC..16	
BLT.100.090.CA2W	1.549,70	100-126	32	80	121	2,12	LMA.100.000.000W	VBL10	5008	4158	GRB6C	5003	CA2-90	124510P	VBL6C	5520P	5005	VBSF 16	CC..12	
BLT.125.090.CA1W	1.765,00	125-162	32	80	121	3,30	LMA.125.000.000W	VBL10L	5008	4158	GRB6	5003	CA1-90	12409P	VBL6C	5515P	5005	VBSF 16	TC..16	
BLT.125.090.CA2W	1.765,00	125-162	32	80	121	3,30	LMA.125.000.000W	VBL10L	5008	4158	GRB6	5003	CA2-90	124510P	VBL6C	5520P	5005	VBSF 16	CC..12	
BLT.160.090.CA1W	1.807,00	160-210	32	80	121	4,30	LMA.160.000.000W	VBL10L	5008	4158	GRB6L	5003	CA1-90	12409P	VBL6C	5515P	5005	VBSF 16	TC..16	
BLT.160.090.CA2W	1.807,00	160-210	32	80	121	4,30	LMA.160.000.000W	VBL10L	5008	4158	GRB6L	5003	CA2-90	124510P	VBL6C	5520P	5005	VBSF 16	CC..12	

CA ..-90

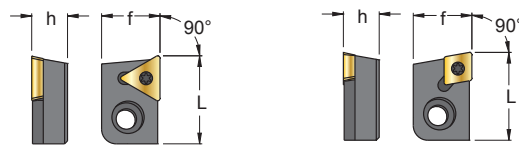

CARTUCCE PER TESTA PER ALESARE BILAMA
 CARTRIDGES FOR TWIN CUTTER BORING HEADS
 EINBAUHALTER FÜR ZWEISCHNEIDEN-AUSDREHKOPF
 CARTOUCHES POUR TÊTE D'ALÉSAGE DOUBLE TRANCHANT

ART.	Prezzo Listino Price List (€)	Prezzi (mm)			kg	Nm	Accessories		Accessories		Accessories	
		f	h	L			16T3	1204	12409P	5515P	VBL06C	5005
CA1-90	112,30	20,0	12,27	30	0,035	3,8+5,0	16T3	-	12409P	5515P	VBL06C	5005
CA2-90	112,30	20,0	12,27	30	0,035	4,0+5,0	-	1204	124510P	5520P	VBL06C	5005



Made In Italy



www.agsautomation.it
info@agsautomation.it



www.bbotools.com
info@bbotools.it



www.sautool.com
infosau@sautool.it

GIBELLINI

www.gibellinicamera.com
info@gibellinicamera.com



www.gis-air.it
info@gis-air.com

**FILIALE DI MODENA
MODENA SUBSIDIARY**

Via Mozart, 47
41122 Modena (MO) Italy
Tel. 0039 059 280706
Fax. 0039 059 280109
saumodena@sautool.it
www.sautool.it

**FILIALE DI TORINO
TORINO SUBSIDIARY**

Strada Vicinale della Cebrosa 86-A
10156 Torino (TO) Italy
Tel. 0039 011 8960193
Fax. 0039 011 8960193
sautorino@sautool.it
www.sautool.it



SAU S.p.A.

Via dei Raseni, 6/B
41040 Polinago (MO) Italy
Tel. 0039 0536 47510
Fax. 0039 0536 47275
infosau@sautool.it
www.sautool.it