

PROMO 2024

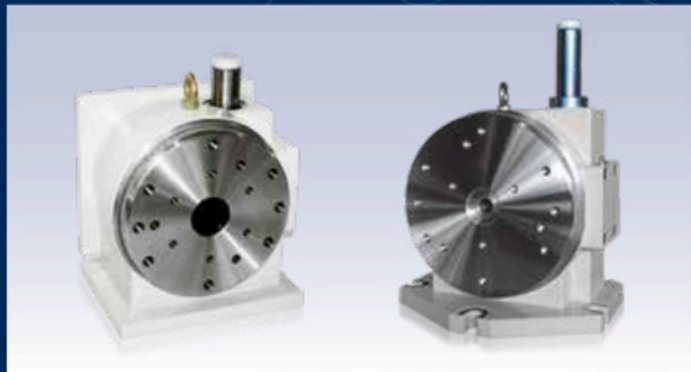

STATIONARY WORKHOLDING

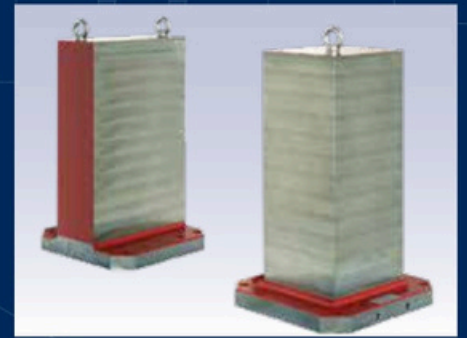
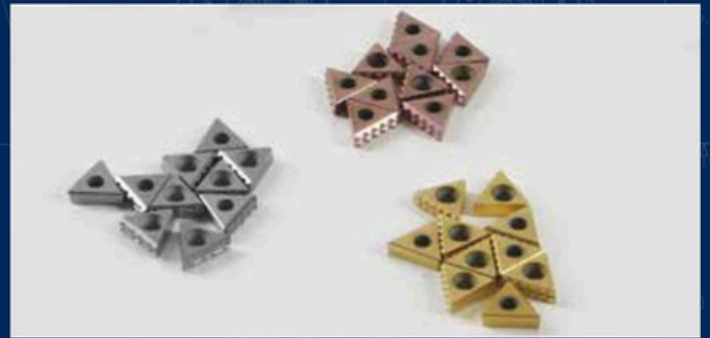

APS 140

Unità di bloccaggio Clamping Unit

- Per macchine a 5 assi
- For 5-axis machining center

READY TO GO



Applicazioni / Benefici cliente

- Unità di bloccaggio pre-assemblata con 4 moduli APS 140 Premium Light o Basic
- Per macchine a 5 assi
- Applicazione universale
- Attrezzaggio veloce e semplice

Caratteristiche tecniche

- 3 griffe di bloccaggio (Basic: 2 griffe di bloccaggio)
- Ripetibilità < 0.005 mm
- Rivestimento di protezione
- Funzione Turbo per incrementare la forza di serraggio (forza di serraggio senza Turbo 7.5 kN)
- Funzione di pulizia (solo Premium Light)
- Interasse 200 mm

Dotazione standard

Unità di bloccaggio con 4 moduli APS 140-E Premium Light o Basic
Rapida connessione pneumatica

Application/customer benefits

- Pre-assembled clamping unit with 4 pieces APS 140 Premium Light or Basic
- For 5-axis machining center
- Universal applicable
- Fast and easy set-up

Technical features

- 3 Clamping slides (Basic: 2 Clamping slides)
- Repeatability < 0.005 mm
- Protective coating
- Turbo function for increasing the pull-in forces (pull-in force without Turbo 7.5 kN)
- Air cleaning (only Premium Light)
- Grid dimension 200 mm

Standard equipment

Clamping unit with 4 modules APS 140-E Premium Light or Basic
Quick pneumatic connections

Codice - Code	Descrizione - Description	Prezzo - Price (€)	Offerta - Offer (€)
46168020	Piastra tonda a 4 moduli APS 140-E Premium Light Round plate with 4 modules APS 140-E Premium Light	5.848,00	4.951,00
46168025	Piastra tonda a 4 moduli APS 140-E Basic NO TURBO Round plate with 4 modules APS 140-E Basic NO TURBO	5.015,00	4.208,00

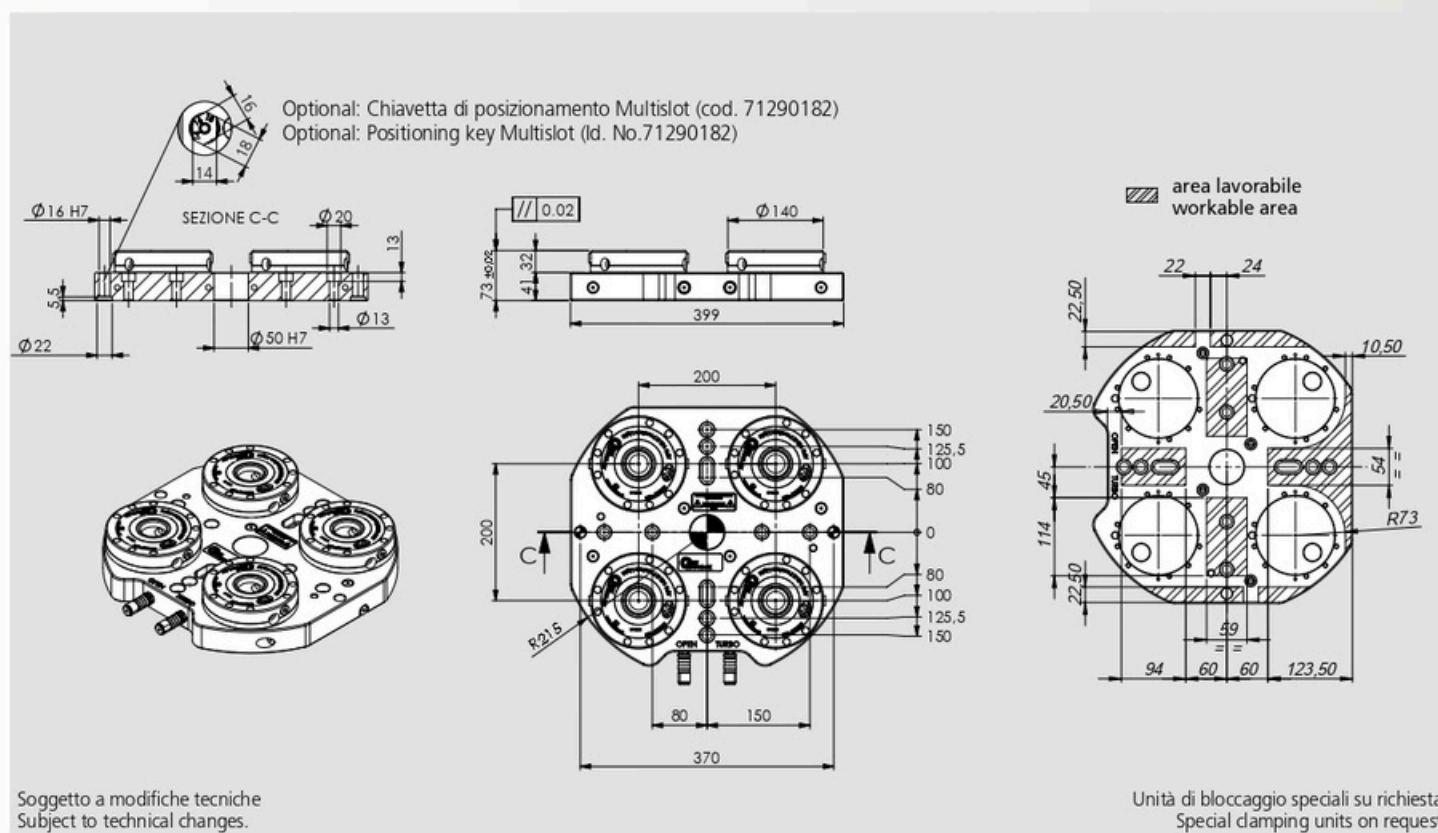

Tipo Type	Codice Id. No.	Forza di bloccaggio Pull-in force kN	Ripetibilità Repeatability	Peso Weight Kg
Unità di bloccaggio con 4 moduli APS 140-E Premium Light Clamping unit with 4 modules APS 140-E Premium Light	46168020	26* (con turbo - with turbo)	< 0.005	45
Unità di bloccaggio con 4 moduli APS-E 140 Basic NO TURBO Clamping unit with 4 modules APS-E 140 Basic NO TURBO	46168025	7,5* (senza - without turbo)	< 0.005	45

* Per ogni modulo - For each module

Unità di bloccaggio Clamping Unit

- Per macchine a 5 assi
- For 5-axis machining center

APS 140

READY TO GO



Applicazioni / Benefici cliente

- Unità di bloccaggio pre-assemblata con 5 moduli APS 140 Premium Light o Basic
- Per macchine a 5 assi
- Applicazione universale
- Attrezzaggio veloce e semplice

Caratteristiche tecniche

- 3 griffe di bloccaggio (Basic: 2 griffe di bloccaggio)
- Ripetibilità < 0.005 mm
- Funzione Turbo per incrementare la forza di serraggio (forza di serraggio senza Turbo 7.5 kN)
- Funzione di pulizia (solo versione Premium Light)
- Interasse 200 mm

Dotazione standard

Unità di bloccaggio con 4 moduli APS140-E Premium Light o Basic + 1 modulo APS140-E Premium

Application/customer benefits

- Pre-assembled clamping unit with 5 pieces APS 140 Premium Light or Basic
- For 5-axis machining center
- Universal applicable
- Fast and easy set-up

Technical features

- 3 Clamping slides (Basic: 2 Clamping slides)
- Repeatability < 0.005 mm
- Turbo function for increasing the pull-in forces (pull-in force without Turbo 7.5 kN)
- Air cleaning (only Premium Light)
- Grid dimension 200 mm

Standard equipment

Clamping unit with 4 modules APS 140-E Premium Light or Basic + 1 modules APS 140-E Premium

Codice - Code	Descrizione - Description	Prezzo - Price (€)	Offerta - Offer (€)
46168040	Piastra tonda a 4 moduli APS140-E Premium Light +1 modulo APS140-E Premium Round plate with 4 mod. APS 140-E Premium Light +1 mod. APS140-E Premium	7.909,00	6.673,00
46168045	Piastra tonda a 4 moduli APS 140-E Basic +1 modulo APS140-E Premium Round plate with 4 mod. APS 140-E Basic +1 mod. APS140-E Premium	7.130,00	6.015,00

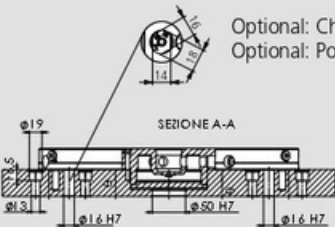

Optional: Chiavetta di posizionamento Multislot (cod. 71290182)
Optional: Positioning key Multislot (Id. No.71290182)

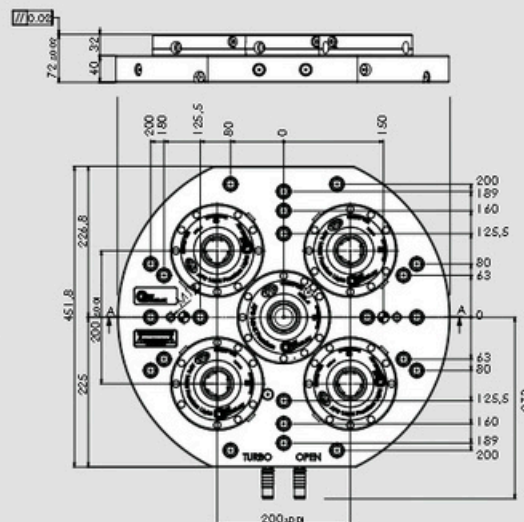
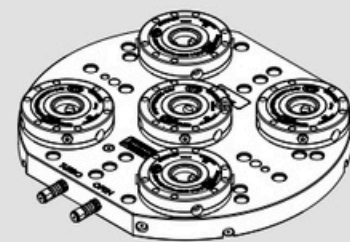

area lavorabile
workable area

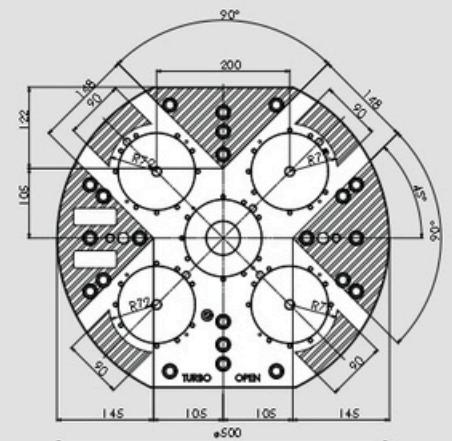

Soggetto a modifiche tecniche
Subject to technical changes.

Unità di bloccaggio speciali su richiesta.
Special clamping units on request.

Tipo Type	Codice Id. No.	Forza di bloccaggio Pull-in force kN	Ripetibilità Repeatability	Peso Weight Kg
Unità di bloccaggio con 4 moduli APS-E 140 Premium Light + 1 modulo APS-E 140 Premium Clamping unit with 4 modules APS 140 Premium Light- 1 module APS-E 140 Premium	46168040	26* (con turbo - with turbo)	< 0.005	68
Unità di bloccaggio con 4 moduli APS 140-E Basic + 1 modulo APS-E 140 Premium NO TURBO Clamping unit with 4 modules APS-E 140 Basic + 1 module APS-E 140 Premium NO TURBO	46168045	7,5* (senza - without turbo)	< 0.005	67

* Per ogni modulo - For each module

V5 88-130

Morsa autocentrante per macchine 5 assi Self-centering vice for 5-axis machines

- Vite protetta brevettata
- Patented protected screw



Applicazioni/Benefici cliente

- Bloccaggio **solo** auto-centrante altamente preciso con la massima ripetibilità
- Totalmente protetta
- Design compatto per una migliore accessibilità e aperture di uscita trucioli molto ampie
- Ganasce con inserti di bloccaggio SinterGrip per una minima profondità di bloccaggio pezzi senza pre-lavorazione
- Ampia gamma di bloccaggio
- Ideale per OP 10 e OP 20

Caratteristiche tecniche

- Bloccaggio auto-centrante
- Forza di bloccaggio fino a 32 kN (50 Nm)
- Larghezza ganasce 87,5 mm
- Interfaccia per sistemi di bloccaggio Zero Point APS / TDM e Plus5 52

Dotazione standard

Chiave di manovra, ganasce, n. 10 inserti Sintergrip.

Applications / Customer Benefits

- Highly precise **only** self-centering clamping with maximum repeatability
- Totally protected
- Compact design for better accessibility and very large drainage slots
- Jaws with SinterGrip clamping inserts for minimum workpiece clamping depth without pre-machining
- Wide clamping range
- Ideal for OP 10 and OP 20

Technical features

- Self-centering clamping
- Clamping force up to 32 kN (50 Nm)
- Jaw width 87,5 mm
- Interface for Zero Point system APS / TDM and Plus5 52

Standard equipment

Wrench, jaws, nr. 10 Sintergrip inserts.

Codice - Code	Descrizione - Description	Prezzo - Price (€)	Offerta - Offer (€)
77583303	V5 88 - 130 con ganasce SinterGrip STD V5 88 - 130 with SinterGrip jaws STD	1.198,00	998,00
77583304	V5 88 - 130 con ganasce SinterGrip HRC V5 88 - 130 with SinterGrip jaws HRC	1.198,00	998,00
77583305	V5 88 - 130 con ganasce SinterGrip ALU V5 88 - 130 with SinterGrip jaws ALU	1.198,00	998,00
77583302	V5 88 - 130 Basic V5 88 - 130 Basic	954,00	795,00
77583301	V5 88 - 130 solo base V5 88 - 130 body only	719,00	599,00

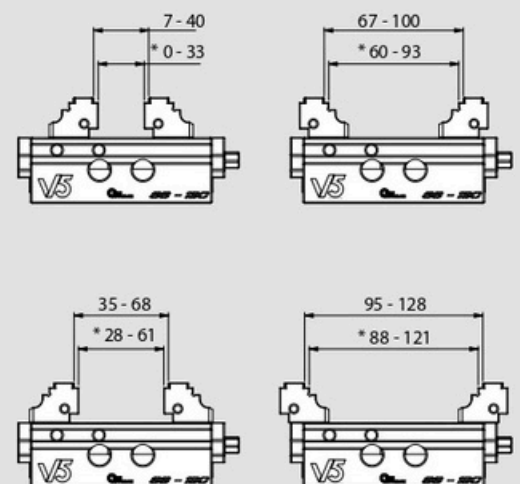
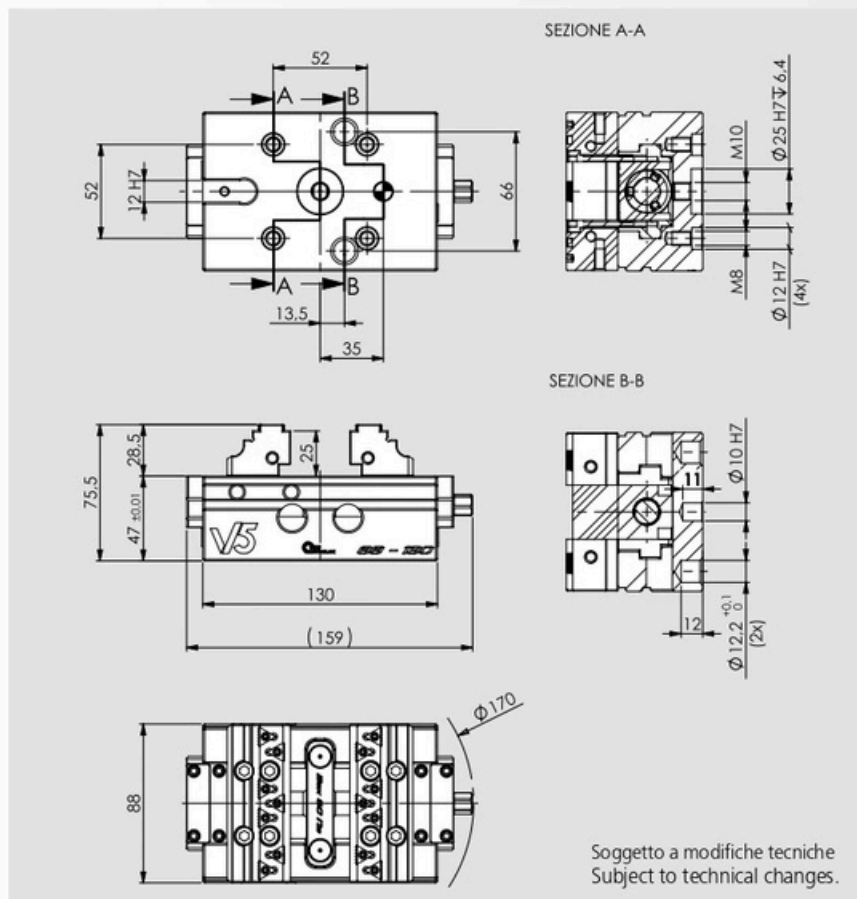

* Apertura con ganasce lisce
Quote valide sia per modelli SinterGrip che Basic

* Opening with smooth jaws
Valid dimensions for both SinterGrip and Basic type

Soggetto a modifiche tecniche
Subject to technical changes.

Morsa autocentrante per macchine 5 assi Self-centering vice for 5-axis machines

- Vite protetta brevettata
- Patented protected screw

V5 125-180



Applicazioni/Benefici cliente

- Bloccaggio **solo** auto-centrante altamente preciso con la massima ripetibilità
- Totalmente protetta
- Design compatto per una migliore accessibilità e aperture di uscita trucioli molto ampie
- Ganasce con inserti di bloccaggio SinterGrip per una minima profondità di bloccaggio pezzi senza pre-lavorazione
- Ampia gamma di bloccaggio
- Ideale per OP 10 e OP 20

Caratteristiche tecniche

- Bloccaggio auto-centrante
- Forza di bloccaggio fino a 40 kN (80 Nm)
- Larghezza ganasce 125 mm
- Interfaccia per sistemi di bloccaggio Zero Point APS / TDM e Plus5 52 - 96

Dotazione standard

Chiave di manovra, ganasce, n. 10 inserti Sintergrip.

Applications / Customer Benefits

- Highly precise **only** self-centering clamping with maximum repeatability
- Totally protected
- Compact design for better accessibility and very large drainage slots
- Jaws with SinterGrip clamping inserts for minimum workpiece clamping depth without pre-machining
- Wide clamping range
- Ideal for OP 10 and OP 20

Technical features

- Self-centering clamping
- Clamping force up to 40 kN (80 Nm)
- Jaw width 125 mm
- Interface for Zero Point system APS / TDM and Plus5 52 - 96

Standard equipment

Wrench, jaws, nr. 10 Sintergrip inserts.

Codice - Code	Descrizione - Description	Prezzo - Price (€)	Offerta - Offer (€)
77583333	V5 125 - 180 con ganasce SinterGrip STD V5 125 - 180 with SinterGrip jaws STD	1.464,00	1.220,00
77583334	V5 125 - 180 con ganasce SinterGrip HRC V5 125 - 180 with SinterGrip jaws HRC	1.464,00	1.220,00
77583335	V5 125 - 180 con ganasce SinterGrip ALU V5 125 - 180 with SinterGrip jaws ALU	1.464,00	1.220,00
77583332	V5 125 - 180 Basic V5 125 - 180 Basic	1.176,00	980,00
77583331	V5 125 - 180 solo base V5 125 - 180 body only	852,00	710,00

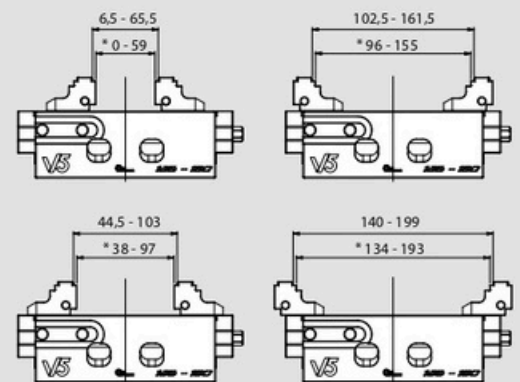
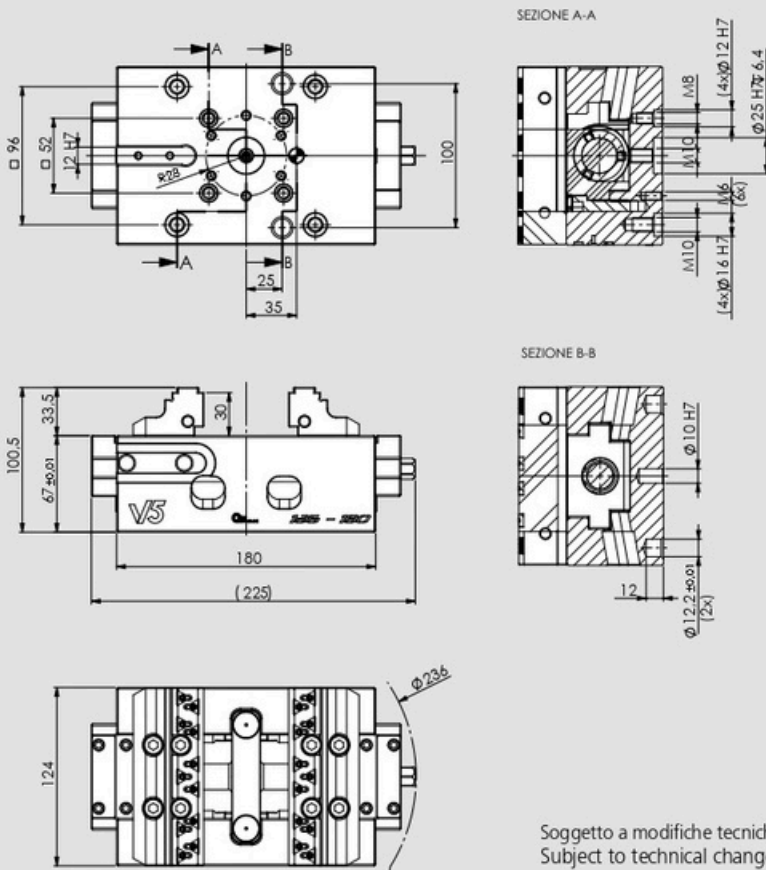

* Apertura con ganasce lisce
Quote valide sia per modelli SinterGrip che Basic

* Opening with smooth jaws
Valid dimensions for both SinterGrip and Basic type

Soggetto a modifiche tecniche
Subject to technical changes.

Attrezzatura di bloccaggio **MC** con: chiave poligonale, ganascia guidata (a richiesta ganascia oscillante), piastrina di fermo laterale, coppia chiavette di posizionamento **h6** a scelta, carter protezione vite, 4 staffe di fissaggio, **coppia di ganasce senza rivestimento in carburo di tungsteno, 1 coppia di parallele CLAK (PP), 1 chiave TORX a bandiera e un set 10 viti**, cassa imballo in cartone. Gli inserti SinterGrip **non sono inclusi**: richiedeteli al vostro rivenditore di fiducia.

Clamping equipment **MC** complete with: wrench, rigid slide way (floating slide-way at request for raw workpiece), work stop, pair of positioning keys **h6**, cover for protection of the screw, 4 clamps, **pair of jaws without tungsten carbide coating, 1 pair of parallels (PP), 1 wrench TORX T9 and 1 kit of 10 screws**, cardboard box. SinterGrip inserts **are not included**: ask to your local dealer.



Codice - Code	Prezzo - Price (€)	Offerta - Offer (€)
33 58 06 51	1.769,00	1.346,00
33 58 06 52	1.833,00	1.451,00
33 58 06 53	2.129,00	1.530,00
33 58 07 51	2.854,00	2.448,00
33 58 07 52	3.305,00	2.644,00



Codice - Code	Descrizione - Description	
58450119	Set 10 inserti STD per acciaio Set of 10 inserts STD for steel	
	€ 278,00	€ 239,00
58450129	Set 10 inserti HRC per acciaio temperato - titanio Set of 10 inserts HRC for hardened steel - titanium	
	€ 278,00	€ 239,00
58450139	Set 10 inserti ALU per alluminio Set of 10 inserts ALU for aluminium	
	€ 278,00	€ 239,00

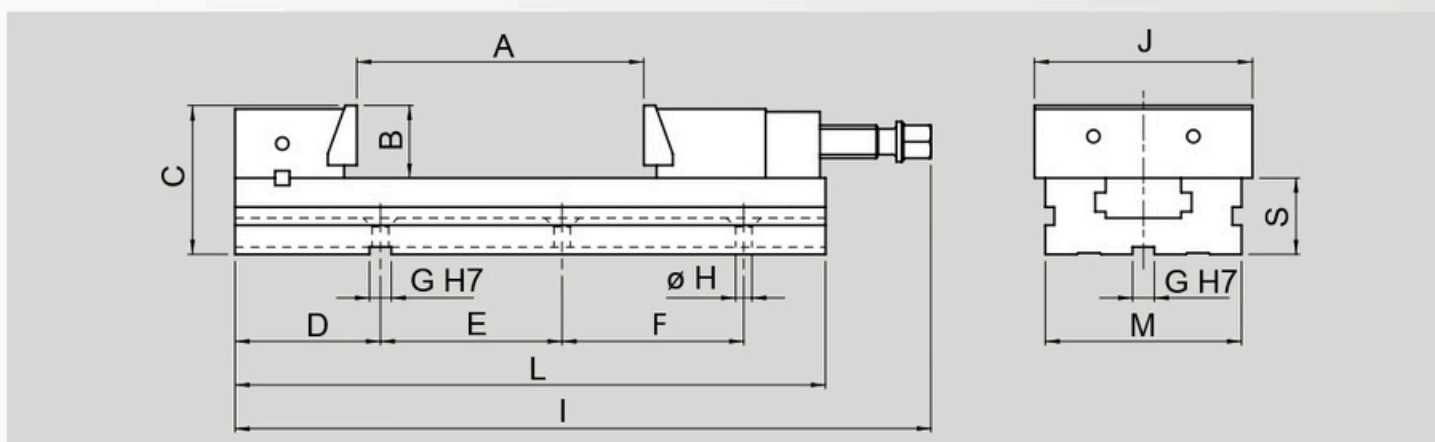

Codice Code	Modello Type	A	B	C	D	E	F	G	H	I	J	L	M	S	Peso Weight
		mm	mm	mm	mm	mm	mm	mm	mm	mm	mm	mm	mm	mm	Kg
33580651	MC 150 x 200	200	50	102	120	200	-	18	12,5	482	150	415	128	52	25,5
33580652	MC 150 x 250	250	50	102	120	100	100	18	12,5	532	150	465	128	52	27,5
33580653	MC 150 x 300	300	50	102	120	100	100	18	12,5	587	150	520	128	52	30,4
33580751	MC 200 x 300	300	70	136	150	150	150	18	12,5	656	200	570	168	66	66,0
33580752	MC 200 x 400	400	70	136	150	200	200	18	12,5	756	200	670	168	66	68,0

La nuova MORSA **LC** si affianca alle originali OML TC e MC come soluzione "low cost".

The new **LC** VISE joins the original OML TC and MC VISES as "low cost" solution.



Codice - Code	Descrizione - Description	Prezzo - Price (€)	Offerta - Offer (€)
77589501	Attrezzatura di bloccaggio LC 125x150 - Clamping equipment LC 125x150	821,00	677,00
77589601	Attrezzatura di bloccaggio LC 150x200 - Clamping equipment LC 150x200	994,00	825,00
77589602	Attrezzatura di bloccaggio LC 150x300 - Clamping equipment LC 150x300	1.213,00	965,00
77589701	Attrezzatura di bloccaggio LC 200x300 - Clamping equipment LC 200x300	1.976,00	1.642,00
77589702	Attrezzatura di bloccaggio LC 200x400 - Clamping equipment LC 200x400	2.372,00	1.930,00

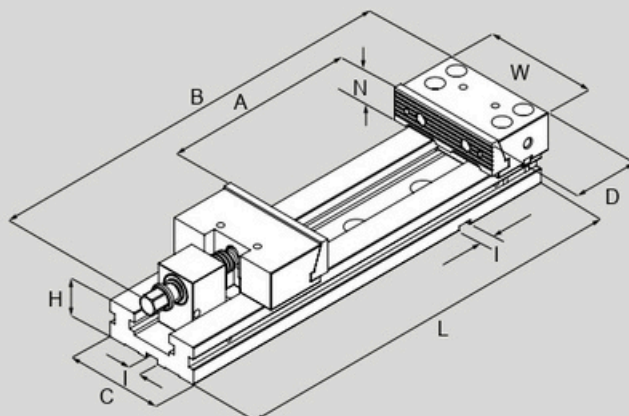

Codice Code	Modello Type	W	N	A	L	B	C	D	H	I	Peso Weight
		mm	mm	mm	mm	mm	mm	mm	mm	mm	Kg
77589501	LC 125 x 150	125	40	150	345	410	95	77,9	40	16	13
77589601	LC 150 x 200	150	50	200	420	500	125	89,4	50	16	26
77589602	LC 150 x 300	150	50	300	520	600	125	89,4	50	16	29
77589701	LC 200 x 300	200	65	300	595	680	170	113,0	70	16	69
77589702	LC 200 x 400	200	65	400	695	780	170	113,0	70	16	74

SinterGrip: THE NEW CHOICE

SinterGrip sono inserti in metallo duro sintetizzato tipo ISO P30:P35 e rivestito con metodo PVD.

SinterGrip are solid carbide serrated inserts type ISO P30:P35 and coated with method PVD.



	Codice - Code	Descrizione - Description	Prezzo - Price (€)	Offerta - Offer (€)
	58450119	Set 10 inserti SINTERGRIP STD (giallo) Set 10 ins. SINTERGRIP STD (yellow)	278,00	239,00
	58450129	Set 10 inserti SINTERGRIP HRC (bronzo) Set 10 ins. SINTERGRIP HRC (bronze)	278,00	239,00
	58450139	Set 10 inserti SINTERGRIP ALU (argento) Set 10 ins. SINTERGRIP ALU (silver)	278,00	239,00

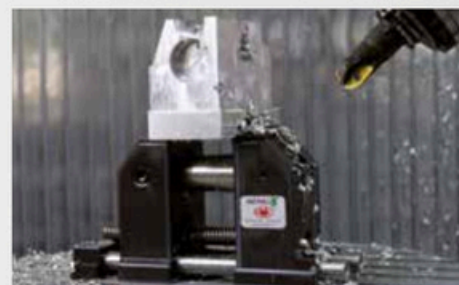
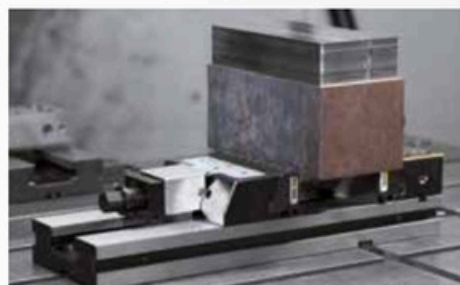

Set ganasce per SinterGrip Jaws set for SinterGrip

GANASCE JAWS

Coppia di ganasce senza rivestimento in carburo di tungsteno. Il set comprende una coppia di ganasce, 1 coppia di parallele CLAK (PP), 1 chiave TORX a bandiera e un set 10 viti.

Pair of jaws without tungsten carbide coating. The set includes one pair of jaws, 1 pair of parallels (PP), 1 wrench TORX T9 and 1 kit of 10 screws.



Codice - Code	Descrizione - Description	Prezzo - Price (€)	Offerta - Offer (€)
58451219	Coppia ganasce OML TC/MC 150 STANDARD Pair of jaws OML TC/MC 150 STANDARD	349,00	279,00

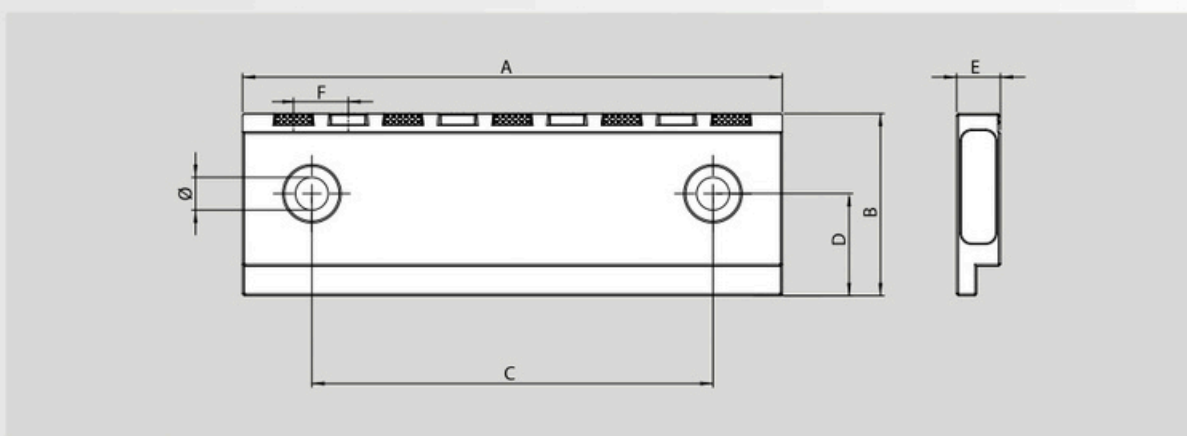

Codice Code	Modello Type	A	B	C	D	D1	E	Ø	H parall.	F	n. inserti n° inserts
58451219	OML - TC/MC 150 mm	mm 148	mm 50	mm 110	mm 28	mm -	mm 12	mm 9	mm 47	mm 15	9

CUBI TOMBSTONE

Cubi sgrossati Tombstone rough milled



I cubi e le spalle in offerta sono in fusione di ghisa GJL 300. Il prezzo include la lavorazione per l'interfaccia al pallet della macchina utensile come da normativa JIS, (macchine utensili giapponesi), e la sgrossatura delle facce con 4 mm di sovrametallo sul totale.

A richiesta la base può essere lavorata secondo specifiche del cliente.

The tombstones and the crankwebs in the offer are in cast iron GJL 300. The price includes the working for the adaptation to the machine tool pallet according to the JIS specifications, (Japanese machine tools), and the faces are rough milled with 4 mm of overall material.

Upon request the base can be machined following customer's specifications.

Codice - Code	Descrizione - Description	Prezzo - Price (€)	Offerta - Offer (€)
57406036	Cubo sgrossato ghisa 400x660 C=256 Cast iron tombstone rough milled 400x660 C=256	4.043,00	2.027,00
57406056	Cubo sgrossato ghisa 500x700 C=356 Cast iron tombstone rough milled 500x700 C=356	5.533,00	2.703,00
57406091	Cubo sgrossato ghisa 630x860 C=456 Cast iron tombstone rough milled 630x860 C=456	7.840,00	4.287,00
57406121	Cubo sgrossato ghisa 800x1000 Cast iron tombstone rough milled 800x1000	10.955,00	8.475,00

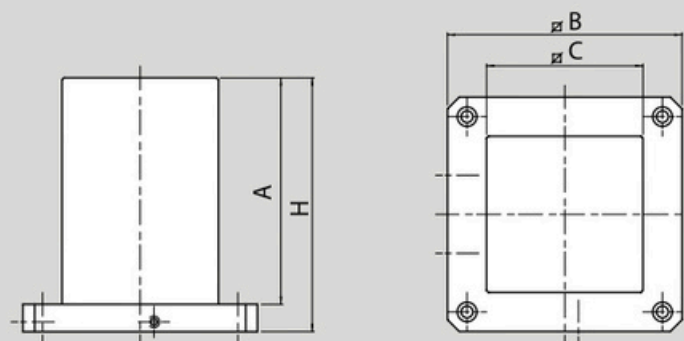

Ghisa - Cast iron

Codice - Code	A	B	C	H	Peso - Weight
	mm	mm	mm	mm	Kg
57406036	615	400	254	660	220
57406056	655	500	354	700	329
57406091	810	630	454	860	607
57406121	945	800	554	1000	808

Spalle sgrossate Crankwebs rough milled

SPALLE CRANKWEBS

I cubi e le spalle in offerta sono in fusione di ghisa GJL 300. Il prezzo include la lavorazione per l'interfaccia al pallet della macchina utensile come da normativa JIS, (macchine utensili giapponesi), e la sgrossatura delle facce con 4 mm di sovrametallo sul totale.

A richiesta la base può essere lavorata secondo specifiche del cliente.

The tombstones and the crankwebs in the offer are in cast iron GJL 300. The price includes the working for the adaptation to the machine tool pallet according to the JIS specifications, (Japanese machine tools), and the faces are rough milled with 4 mm of overall material.

Upon request the base can be machined following customer's specifications.



Codice - Code	Descrizione - Description	Prezzo - Price (€)	Offerta - Offer (€)
57409026	Spalla sgrossata ghisa 400x660 Cast iron crankweb rough milled 400x660	4.013,00	2.027,00
57409046	Spalla sgrossata ghisa 500x700 Cast iron crankweb rough milled 500x700	5.533,00	2.702,00
57409066	Spalla sgrossata ghisa 630x860 Cast iron crankweb rough milled 630x860	7.840,00	4.287,00
57409091	Spalla sgrossata ghisa 800x1000 Cast iron crankweb rough milled 800x1000	10.955,00	8.475,00

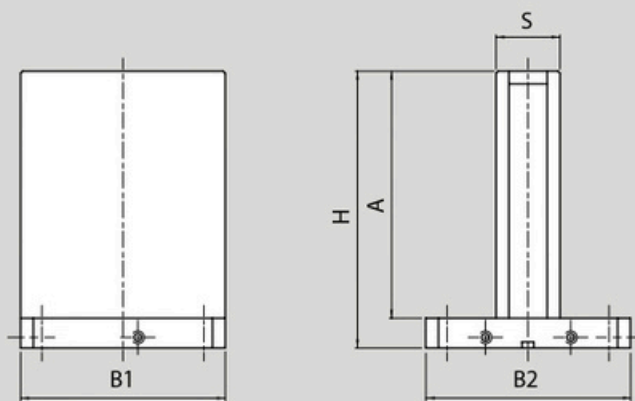

Ghisa - Cast iron

Codice - Code	A	B	H	S	Peso - Weight
	mm	mm	mm	mm	Kg
57409026	615	400	660	154	209
57409046	655	500	700	154	265
57409066	810	630	860	204	485
57409091	945	800	1000	304	810

TETRABLOK

Attrezzatura di bloccaggio a 4 posizioni 4 positions clamping equipment

L'attrezzatura di bloccaggio a 4 posizioni **TETRABLOK** si affianca a CIVI 2000 con un ottimo rapporto qualità/prezzo. Attrezzatura di bloccaggio a 4 posizioni costituita da n. 1 base di lunghezza a scelta, n. 1 supporto fisso, n. 4 elementi di bloccaggio, n. 4 fermi laterali, n. 1 coppia chiavette posizionamento, n. 1 chiave a T.

The 4 workpieces clamping equipment **TETRABLOK** joins CIVI 2000 with a good price/quality ratio.

Tetrablok 4 workpieces clamping equipment complete with n. 1 base (length optional); n. 1 fixed support; n. 4 clamping units; n. 4 workstops; n. 1 pair of positioning keys; n. 1 T-wrench.

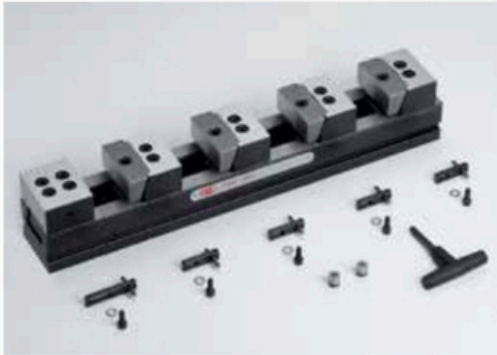

Codice - Code		Prezzo - Price (€)	Offerta - Offer (€)
77588101	TETRABLOK 60 L400	1.922,00	1.112,00
77588102	TETRABLOK 60 L500	2.184,00	1.252,00
77588103	TETRABLOK 60 L630	2.362,00	1.378,00
77588201	TETRABLOK 90 L400	2.448,00	1.393,00
77588202	TETRABLOK 90 L500	2.628,00	1.524,00
77588203	TETRABLOK 90 L630	2.821,00	1.657,00

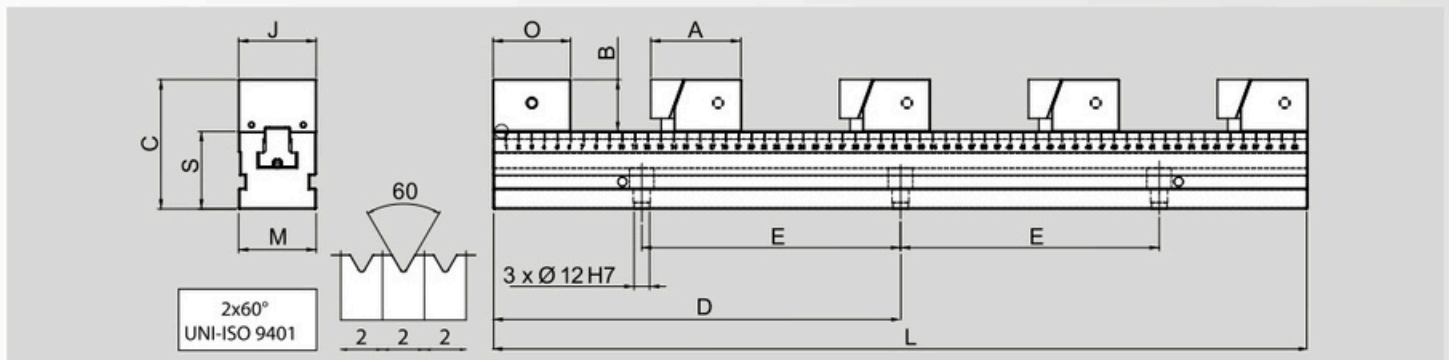

Codice Code	Modello Type	A	B	C	D	E	J	L	M	O	S ± 0,01	Peso Weight
77588101	Tetrablok 60	mm	mm	mm	mm	mm	mm	mm	mm	mm	mm	Kg
77588102		70	40	100	200	100	60	400	60	60	60	16,9
77588103		70	40	100	250	150	60	500	60	60	60	19,9
77588201	Tetrablok 90	80	45	115	200	100	90	400	90	70	70	27,6
77588202		80	45	115	250	150	90	500	90	70	70	32,8
77588203		80	45	115	315	200	90	630	90	70	70	36,7

Capacità di serraggio - Clamping capacity

Modello - Type	A max			
	mm	mm	mm	mm
TETRABLOK / 60-400	270	100	43	15
TETRABLOK / 60-500	370	150	76	40
TETRABLOK / 60-630	500	215	120	73
TETRABLOK / 90-400	249	84	29	-
TETRABLOK / 90-500	349	134	62	26
TETRABLOK / 90-630	479	199	106	59

Cubo croce con Tetrablok
Cross tombstone with Tetrablok

CUBI
TOMBSTONE

Cubo a croce in acciaio
 con 4 TETRABLOK 60/90-630 mm

Steel cross tombstone
 with 4 TETRABLOK 60/90-630 mm



Codice - Code	Descrizione - Description	Prezzo - Price (€)	Offerta - Offer (€)
33588101	Cubo croce P400 con 4 TETRABLOK 60/630 Cross cube P400 with 4 TETRABLOK 60/630	13.099,00	8.274,00
33588102	Cubo croce P500 con 4 TETRABLOK 60/630 Cross cube P500 with 4 TETRABLOK 60/630	13.331,00	8.728,00
33588201	Cubo croce P400 con 4 TETRABLOK 90/630 Cross cube P400 with 4 TETRABLOK 90/630	15.247,00	9.405,00
33588202	Cubo croce P500 con 4 TETRABLOK 90/630 Cross cube P500 with 4 TETRABLOK 90/630	15.555,00	9.859,00

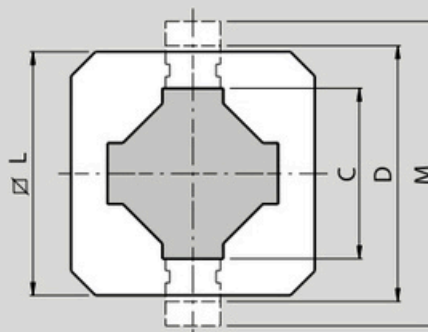
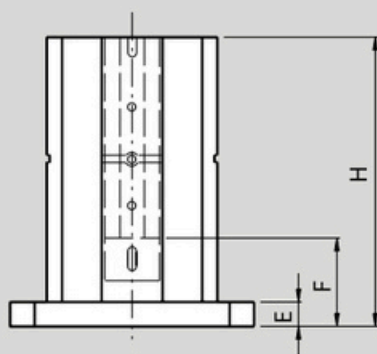

Acciaio - Steel		C	D	E	F	H	L	M	Peso - Weight
Codice - Code	Modello - Type	mm	mm	mm	mm	mm	mm	mm	Kg
33588101	TETRABLOK 60/630	250	370	40	120	690	400	450	230
33588102	TETRABLOK 60/630	300	420	40	120	690	500	500	275
33588201	TETRABLOK 90/630	250	390	40	130	690	400	480	289
33588202	TETRABLOK 90/630	300	440	40	130	690	500	530	334



Tavole a indexaggio meccanico non motorizzate ad attuazione programmabile indiretta

Automatic mechanical indexing tables

Codice - Code	Descrizione - Description	Prezzo - Price (€)	Offerta - Offer (€)
51991301	Tavole indexate TOUCHDEX FDM 150 Index tables TOUCHDEX FDM 150	5.413,00	4.599,00



Tavole a indexaggio meccanico non motorizzate ad attuazione programmabile indiretta

Automatic mechanical indexing tables

Codice - Code	Descrizione - Description	Prezzo - Price (€)	Offerta - Offer (€)
51991302	Tavole indexate TOUCHDEX FD 200-04 Index tables TOUCHDEX FD 200-04	6.767,00	5.748,00

RIGIDITÀ

L'esclusivo sistema "Touchdex" consente l'applicazione di una forza di bloccaggio da 2 a 3 volte superiore rispetto al sistema in uso sulle tavole CNC.



RIGIDITY

The exclusive "Touchdex" system provides a clamping force 2 to 3 times that an ordinary index table thus allowing heavy machining.

PRECISIONE

Posizionamento angolare 30 sec.
 Ripetibilità del posizionamento ± 3 sec.

PRECISION

Indexing accuracy of less then 30 sec.
 Repeat accuracy ± 3 sec.

ECONOMICITÀ

MINIMUM INVESTMENT

ESTREMA VERSATILITÀ

L'assenza di collegamenti elettrici, pneumatici o idraulici ne permette l'utilizzo anche su centri di lavoro multipallet sia orizzontale sia verticali.

VERSATILITY

Since it has no electric or pneumatic connections, it can be installed on multi-pallet machining centers either vertical or horizontal with the possibility to create flexible production system.

FUNZIONAMENTO

Non appena la barra di spinta viene premuta, il perno di bloccaggio si ritrae grazie al suo meccanismo zigrinato a cam.

Premendo ulteriormente la barra di spinta, la tavola inizia a ruotare.

Sino a che la barra di spinta non ha concluso la sua corsa di ritorno, la tavola e il perno di bloccaggio rimangono in posizione.

Conclusa la sua corsa di ritorno, il perno di bloccaggio si innesta con la ghiera di posizionamento e fissa la tavola.

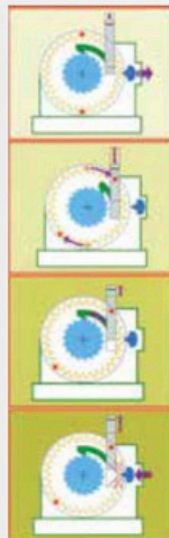

WORKING

When the pushbar is pressed down a little, the lock pin retracts due to a grooved cam mechanism.

When pressed down further, the faceplate begins to rotate

The pushbar returns, but until a certain position is reached the faceplate and the lock pin continue to be as they were.

When the pushbar reaches the highest position, the lock pin engages with the positioning gear and fixes the table.

PROGRAMMAZIONE

L'angolo di indexaggio voluto si ottiene con una differente corsa dell'asse Z della MU in funzione della lunghezza della barra di spinta.

PROGRAM

By means of different strokes of the Z-axis it is possible to reach needed indexing angle.

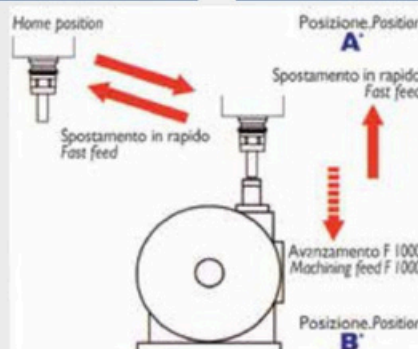

Codice - Code	Modello - Type	Incrementi angolari - Indexing angles		Corsa barra - Pushbar stroke	A
		min.	max	mm	mm
51 99 13 01	FDM - 150	5°	45°	38	127
51 99 13 02	FDM - 200-04	5°	90°	78	208

IMG

IMAGINATION HAS NO LIMIT



Ganasce SinterGrip
SinterGrip jaws



Ganasce SinterGrip:
ganasce reversibili per la minima profondità di bloccaggio e senza pre-lavorazione

SinterGrip jaws:
Reversible jaws for minimum clamping depth and without pre-machining



Ganasce BASIC
BASIC jaws

Ganasce BASIC:
per modello **IMG BASIC** (senza l'utilizzo di inserti Sintergrip)

BASIC jaws:
for **IMG BASIC** model (without the use of Sintergrip inserts)



Gamma di serraggio molto ampia
Massima flessibilità
Per bloccaggio esterno ed interno

Wide clamping range
Maximum flexibility
For external and internal clamping



Bloccaggio meccanico
Totalmente protetta con sistema telescopico brevettato.
La grande trasmissione di forza consente elevate prestazioni nel processo di lavorazione

Mechanical clamping
Totally protected with patented telescopic system.
The large power transmission allows high performance in the manufacturing process

Interfaccia
per sistemi di bloccaggio zero point e fori di montaggio come standard

Interface
For Zero Point clamping systems and mounting holes as standard

- **Totamente protetta**
con sistema telescopico
brevettato
- **Totally protected**
With patented telescopic
system



- **Fori passanti**
per bloccaggio
frontale
- **Through holes**
For frontal clamping



Scopri di più



Find out more

- **Ideale**
per automazione e
sistemi di pallettizzazione
- **Ideal**
For automation and
palletizing systems

- **Montaggio flessibile**
su tavola macchina
tramite staffe (opzionale)
- **Flexible mounting**
on machine tool pallet using
clamps (optional)

Ganascia doppio bloccaggio
Double clamping jaw
(for double clamping)



Piastra di fermo
Retainer plate
(for fixed clamping)



- **Aperture di uscita trucioli molto ampie**
per garantire un flusso di trucioli ottimizzato
- **Very large drainage slots**
for coolant and chips

- **Guide trattate e rettificate di precisione**
per la massima precisione e ripetibilità
- **Treated and precision ground guides**
for maximum accuracy and repeatability

- **Parallele**
a ricambio rapido Clak System
- **Parallels**
with quick change Clak System

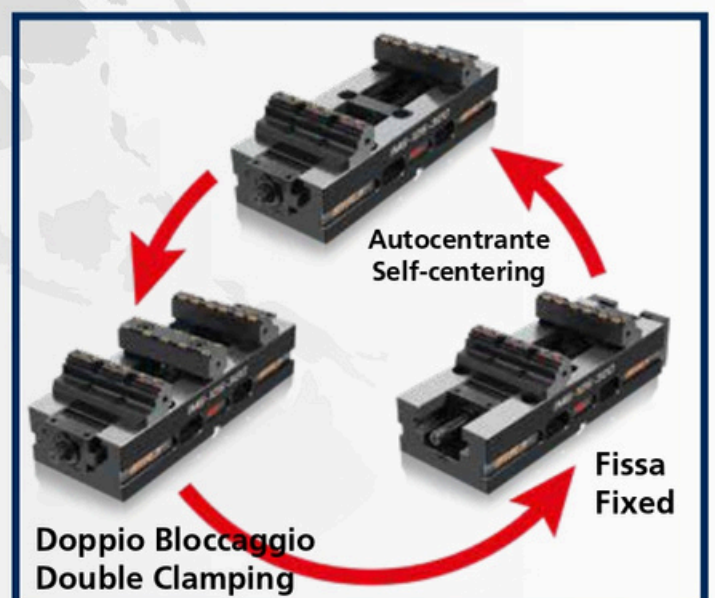



APS è il sistema d'interfaccia universale tra la macchina utensile, l'attrezzatura di bloccaggio e/o direttamente il pezzo da lavorare.

La flessibilità del sistema APS consente il posizionamento ed il bloccaggio in un'unica operazione con ripetibilità < 0,005 mm.

APS is a universal connection between the machine tool, the clamping device and/or the workpiece.

Positioning and clamping in one operation with repeatability accuracy < 0,005 mm (0.0002").

**I vostri tempi di attrezzaggio si ridurranno del 90%.
Your set-up times will be reduced by 90 %.**



SISTEMA DI BLOCCAGGIO A 3 GRIFFE a 120°

APS 140 Premium è l'UNICO sistema di bloccaggio ZERO POINT a 3 griffe a 120°.

CLAMPING SYSTEM WITH 3 JAWS AT 120°

APS is the only one clamping system ZERO POINT with 3 jaws at 120°.



INNOVATIVO TRATTAMENTO ANTIATTRITO E ANTICORROSIONE

Per mantenere la durezza 62 HRC agli elementi principali del bloccaggio (non realizzabile con l'acciaio INOX) abbiamo applicato un innovativo sistema antiattrito e anticorrosione ai perni e alle griffe.

INNOVATIVE ANTIFRICTION AND ANTICORROSION TREATMENT

To maintain the hardness 62 HRC to the main lock elements (not possible with stainless steel), we applied an innovative anti-friction and anti-corrosion system to the pins and jaws.

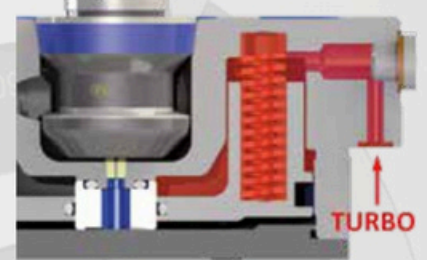

FUNZIONE TURBO INTEGRATA

Turbo è la funzione per mezzo della quale l'aria compressa incrementa la forza di bloccaggio "PULL DOWN" esercitata dalle molle fino a 30.000 N.

TURBO FUNCTION INTEGRATED

Turbo is the function by means of which the compressed air increases the clamping force applied by the springs until reaching the "PULL DOWN" clamping force of 30,000 N.

FOLLOW THE RED LINE

TdM

Torque Die & Mold

PATENT
PENDING



Solo 3,5 rotazioni
per bloccaggio/sbloccaggio
Only 3.5 rotation Lock-Unlock

Ripetibilità <0,005 mm
Repeatability <0,005 mm

Forza di tenuta fino a 100Kn (TDM 88)
Forza di tenuta fino a 5 Kn (TDM 48)
Holding force up to 100 Kn (TDM 88)
Holding force up to 50 Kn (TDM 48)

Ampia superficie delle griffe
- Forza bloccaggio Pull Down 18Kn a 20Nn (TDM 88)
- Forza bloccaggio Pull Down 8Kn a 12Nn (TDM 48)
High jaws surface contact
- Pull down force 18Kn at 20Nm (TDM 88)
- Pull down force 8Kn at 12Nm (TDM 48)

Ganasce autocentranti Auto-compensanti
Self centered self compensating jaws

VEDI IL VIDEO



WATCH THE VIDEO



Caratteristiche tecniche e dimensioni non impegnative. OML S.r.l. si riserva di apportare in ogni momento eventuali modifiche.
Technical characteristics and dimensions are not obliged. OML S.r.l. may give in every time some modifications

Code 10 70 58 47 - PROMO 2024 - printed february 2024



TCI



MCI



CV



CV-S



FMS



SINTERGRIP



APS



CLAK SYSTEM



GENIUS



CAM SYSTEM



HOLDING CLAMPS



VARI CLAMP

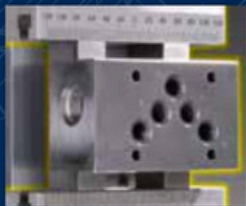

JAWS



SINTEX



FAST CLAMPS



TWIN VISE



IMG



TDM



A COMPANY OF THE GROUP



OFFICINA MECCANICA LOMBARDA S.r.l.



Offerte Speciali fino ad esaurimento scorte • Special Offers until end of the stock